

BaneBots, LLC

BB-3-9 Brushed Motor Controller
9 Amp Peak, 3.5 Amp Continuous
Full Current Limit & Self Protection
Manual – R1.0A



Description

The BB-3-9 is a self protected brushed PM motor controller that provides forward, reverse (no delay) and brake with proportional speed control. The control is obtained from the output signal from a standard hobby RC receiver. The BB-3-9 includes motor direction and status indicators, +5Vdc BEC (Battery Elimination Circuit) for the hobby receiver, battery and motor lead wires and receiver cable with universal connector.

Main Features

- Ultra compact size and light weight.
- High Current Capability: 9 Amps peak, 3.5 Amps continuous.
- Full over current, over voltage, short circuit and thermal protection on all outputs and BEC.
- Receiver cable (8 inches) with universal plug.
- 20 AWG Silicone Power / Motor lead wires (6 inches).
- Safety start-up and lost signal shut-down.
- Motor brake on direction change. Helps protect gears from over stress. This feature is not noticeable to the user.

General Specifications

Size including heat shrink: 1.2" X .52" X .29"
Weight including wires: 0.33 oz. / 9.4 grams
Weight without wires: 0.12 oz. / 3.3 grams (Reference Only)
Operating Voltage: 6 to 24Vdc

Current Capability:

Test Conditions: +24Vdc, +22°C no air flow, Full Throttle		
Amps	Duration	Limiting Factor
3.5	Continuous	None
5	~ 30 Seconds	Thermal Protection
9	Peak	Over Current Protection

BEC (Battery Elimination Circuit) Output: +5Vdc

BEC Current Output Derating:

- 250mA @ +6Vdc Battery Input Voltage
- 25mA @ +24Vdc Battery Input Voltage

Speed Control: 0-100% PWM Proportional forward and reverse. No reverse delay.

Self Protection Features

The BB-3-9 features full current limit and thermal protection on all outputs. All protection is 'built into' the devices, there is no lag time due to monitoring or feedback which can allow destructive conditions to occur and damage FETs. Over voltage clamping on the outputs helps protect the controller from voltage spikes and over voltage.

The BEC (Battery Elimination Circuit) incorporates thermal protection and short circuit / overload protection.

Safety Features

- Auto safety shutdown when the signal is lost or extreme interference is present. The controller will automatically reactivate when the signal returns.
- 'Center stick' safety start-up. Requires the throttle to be in the center or 'neutral' position before the controller is activated.

Basic Functional Description

Power Up:

The controller will activate after power is applied when neutral throttle position signals are received. This is a built-in safety feature. The READY LED will blink rapidly until these signals are received. When the controller has received these neutral position signals, the READY LED will stay on continuously. The DIR LEDs will activate individually depending on the motor direction.

Lost Signal:

When extreme radio interference is present or if the signal is lost, the controller will shut down the motor. Normal operation will resume when several good signals are received.

Over Temperature/Current limit:

When any of the motor control FETs reach an over temperature or over current condition, they will enter into a protection mode and shut down. Normal operation will return when the cause of the over temperature or over current is removed. If the over temperature protection was activated, normal operation will resume when the temperature of the FET (s) has cooled.

Shorted or Stalled Motor:

If this condition occurs and the resulting current draw is greater than 9 Amps typical, the controller will enter into a current limit condition. The time it takes for the controller to enter into temperature limit is based on the amount of current draw if this current is less than 9 Amps.

BaneBots, LLC

BB-3-9 Brushed Motor Controller
9 Amp Peak, 3.5 Amp Continuous
Full Current Limit & Self Protection
Manual – R1.0A



Warnings and Precautions

- The controller may be HOT after use. Use precautions when handling the controller after use.
- Do NOT reverse the battery polarity. This product does not have reverse polarity protection.
- Placing this controller near batteries or motors that increase in temperature when operating will decrease the maximum capability of the controller. This controller has over temperature protection. Close proximity to hot components will reduce the controller capability.

Connections and Hook-Up Instructions

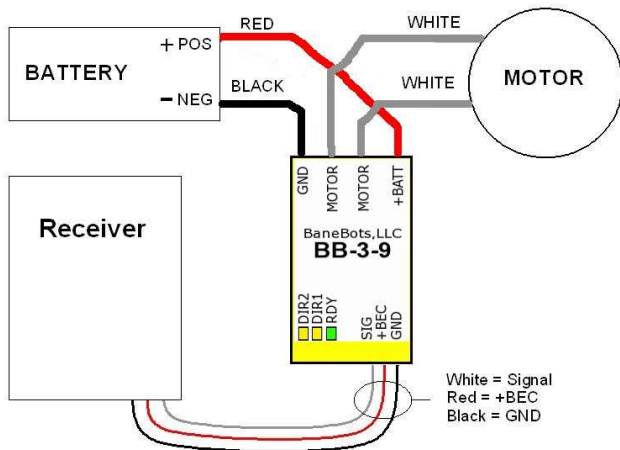

Additional Considerations

It may be necessary to reduce the noise generated from the motor brushes by installing capacitors on the rear of the motor (see diagram below). Typically, three .1 μ F 50V ceramic capacitors are sufficient.

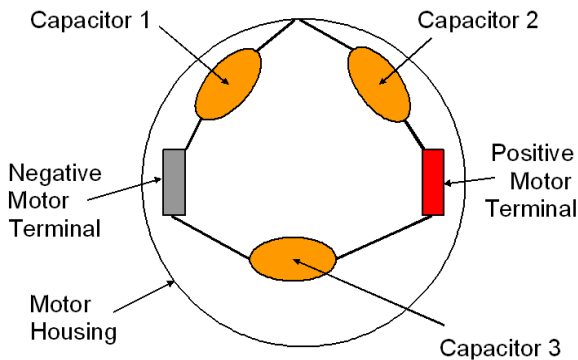

Troubleshooting

In the dual configuration, one motor turns on before the other motor when going forward/reverse – or – one motor seems to go faster than the other motor when they should be going the same speed.

First, make sure that the motors are un-timed motors. Timed motors will have different speeds in the clock wise (CW) and counter clock wise (CCW) directions. If the motors are un-timed, the center stick timing from the receiver may be slightly different for each channel. Use the trim adjustments on the transmitter and the DIR LEDs on the controller to adjust the trim.

When the transmitter throttle is in the center position (center stick), the motor turns on.

Adjust the transmitter trim settings on the transmitter until the motor stops in the center stick position. The DIR LEDs on the BB-3-9 can be used to aid in setting the trim adjustment.

Everything seems to be wired correctly but nothing happens and the LEDs do not come on.

Disconnect the power immediately. Make sure that a power leads are not connected to a motor output on the BB-12-45. Next, make sure that the battery connections are not reversed. Double check that the receiver-to-controller servo leads are correct.

Nothing happens when power is applied and the READY LED blinks continuously.

If all the connections look correct, make sure that the trim adjustments on the transmitter are correct and that the throttle is in the center or neutral stick position. If the READY LED still blinks, slightly adjust the transmitter trim settings until the READY LED stays on continuously.

Warranty / Returns

All products purchased through the BaneBots.com website (herein "item") are warranted to be free of all defects in material and workmanship for a period of 30 days (herein the "Warranty Period") following the date of shipment of the item to the customer. Within the period of this warranty, BaneBots.com will repair or replace a defective item. This warranty does not apply to any defects caused by negligence, misuse, or accidents. The buyer must notify BaneBots.com of any defect, malfunction, or nonconformity promptly upon discovery, and in any case, within the Warranty Period.

In the event that a manufacturing defect is discovered within the Warranty Period, BaneBots.com will repair or replace the defective item, and return the repaired or replacement item to the customer at no charge. The customer is responsible for shipping cost to return any item within the Warranty Period. **NO ITEM MAY BE RETURNED FOR REPAIR OR REPLACEMENT WITHOUT THE PRIOR WRITTEN AUTHORIZATION OF BANEBOTS.COM.** A return authorization may be obtained by contacting BaneBots.com, and obtaining a written Return Authorization.